

AUTOMATIC CONTROL OF A HIGH TENSION ROLL SEPARATOR

P. DE WAAL AND F.E. DU PLESSIS
Blue Cube Systems Pty Ltd, Stellenbosch, South Africa

Through the development of innovative in-line mineral quantification sensors, the possibility has arisen to apply modern control theory to implement automatic process control for electrostatic high tension (“HT”) roll separators. A pilot-scale set-up was constructed to enable continuous tests to be carried out. A typical dry mill feed was continuously pre-heated and separated with a modern lab scale HT roll machine. The mineralogy as well as mass-flow of the non-conductor stream was quantified in-line, and the combined streams were re-circulated in an endless loop by a combination of vibration feeders and a bucket elevator.

A fractional factorial experiment was executed to determine the most significant control parameters of the HT roll separator. Then a multi-input, multi-output dynamic model of the HT electrostatic separator was extracted by the application of standard system identification techniques for automatic control. The most important control variable to ensure a stable product grade could be identified. This allowed a robust single-input, single-output controller to be implemented. The process variable and set-point was mineral grade and the control variable was electrode voltage.

Roll speed was manually adjusted while the mineral grade was kept on set-point by the control system. The roll speed, where maximum mass flow and therefore maximum yield was produced on-grade, could therefore be rapidly determined.

Atmosphere humidity and ore temperature served as disturbances. Some other adjustable parameters were kept constant during the experiments, namely feed mineralogy, splitter settings and feed rate.

Delivery of maximum yield, with a controlled grade, can improve production while reducing the burden of complex manual tuning. Manual tuning previously involved coping with multiple parameters with uncertain cross coupling influences on the end result. Even the end result was typically only known after completion of mineral assays.

Automatic grade stabilisation and yield optimisation for a HT roll separator bank requires in-line measurement of mineralogy and mass flow, as well as the implementation of a robust process control system.

Introduction

HT roll separators are commonly used to upgrade dry mineral mixtures on the basis of different electrical conductivities. A schematic outline of such a unit is given in Figure 1.

An electrically charged plate exerts a push force on the non-conductors to assist their attachment to the roller. The non-conductors rotate with the roller towards the rear where an earthed brush removes the particles. Conductive particles, assisted by centrifugal force and gravity, are flung forward off the roller and drop off the front. Adjustable splitter flaps at the bottom, before the exit, assist towards defining suitable transition points between “conductors”, “middlings” and “non-conductors”.

Although the terms “conductors” and “non-conductors” are often used, the difference is usually not sharp. Electrical conductivity of minerals varies widely and is also seldom found in sharply different bands. It is common for a mineral species to occur with its conductivity in a fairly wide band that may even overlap with that of another mineral species in the same mixture.

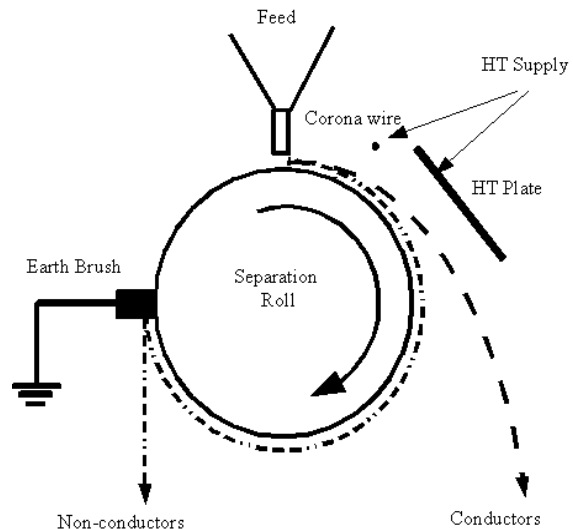

Figure 1: Schematic of a High Tension Roll Separator

Conductivity is also not stable and is influenced by the ore temperature and atmospheric conditions like humidity and temperature.

Some ore conditioning (preheating, drying or coating with some substance) may take place before it is fed into the separator. Although the basic operation of the separator is quite simple, modern machines are typically equipped with a multitude of adjustable options to enable optimised settings for a specific blend of minerals. These can be the ore feed rate, ore temperature, separation drum speed, voltage setting, position of corona wire, position of HT plate and the position of splitter division plates (from one to four or more) below the drum.

All the settings are interdependent and finding the optimum combination becomes a daunting task, even for experienced operators. Manual tuning implies coping with a multitude of parameters with uncertain cross couplings that influence the end result. The tuning of a roll separator is often regarded as a black art, and once a reasonable performance has been achieved, settings are maintained in spite of changed operating conditions.

The absence of real time mineral composition data is a serious limiting factor influencing optimum settings. In line analysers are expensive and usually determine elemental composition, not mineral composition. The actual performance of a mineral separation plant is typically only known after completion of laboratory mineral assays, done on composite shift samples or even composite daily averages.

New Technology

Through the development of innovative in-line mineral quantification sensors, it is now possible to apply modern control theory to implement automatic process control for electrostatic HT roll separators. To prove the concept, a pilot-scale test installation was constructed at the facilities of the Department of Process Engineering at the University of Stellenbosch to enable continuous tests to be carried out in a controlled environment. The pilot plant is shown in Figure 2.

A Carrara laboratory HT Roll Separator is set up to process ore samples in a closed loop. The feed chute is fitted with electrical heating elements by which the feed temperature can be adjusted. The speed of both feed and main roller drive motors can be controlled as well as the setting of the HT voltage. The position of the corona wire, HT plate and splitter flaps on the discharge are all manually adjustable. Mass flow of the feed is measured by calibration of the Carrara feed roller. The splitter plates were set to produce two exit streams only; a “conductor” stream drops off the front of the separation roller, and a “non-conductor” stream is discharged at the earthing brush at the rear of the separation roller. By selecting this setting, there is no middlings stream and the mass balance is simplified. Mass-flow of the conductor stream is measured in-line with a calibrated slot discharge mass flow meter.

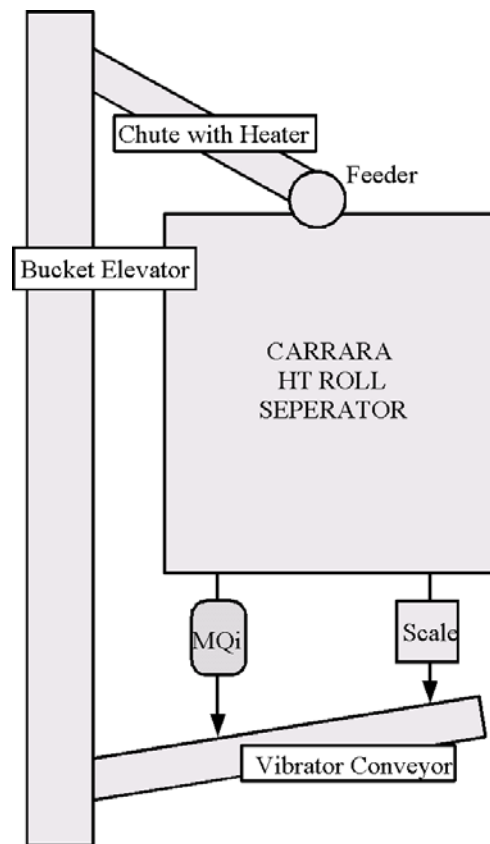

Figure 2: Schematic of Pilot Plant

The product (non-conductor stream) mineralogy is continuously determined with a Blue Cube MQi in-line mineral quantifier and the product mass flow is calculated by the difference between the feed mass flow and the conductor stream mass flow. Both discharge streams are then combined and recirculated in an endless loop by a combination of vibration conveyors and a bucket elevator. The pilot plant was provided with instrumentation and facilities to achieve automatic control and logging of the ore feed mass flow, ore feed temperature, separation drum speed and the high voltage magnitude. In addition, the product mass flow, product grade and relative humidity (inside the Carrara casing) can be logged or used as input to the control program. The actual values of all these settings are logged at one second intervals. The other settings can be adjusted and logged manually.

A sample of typical heavy minerals dry mill feed, with known composition, was continuously circulated to determine the characteristics of the system and to prove the regulation concept.

Sensitivity Tests

Initially the system was set up and ran continuously, with the HT switched off, to homogenise the ore sample. Thereafter the HT was switched on and separation started. Under manual control, parameters were adjusted until

stable operation was achieved. A 2-level fractional factorial experiment for 6 factors was designed and executed. The kV values were set at 18kV and 23kV; The roller speed at 35 and 70 Hz; The feed at 10 and 30Hz and

the temperature at 30 and 60°C. It yielded the correlation factors as shown in Figure 3. The initial experiment showed that the separator roll speed and HT voltage setting has the most significant impacts on the product grade.

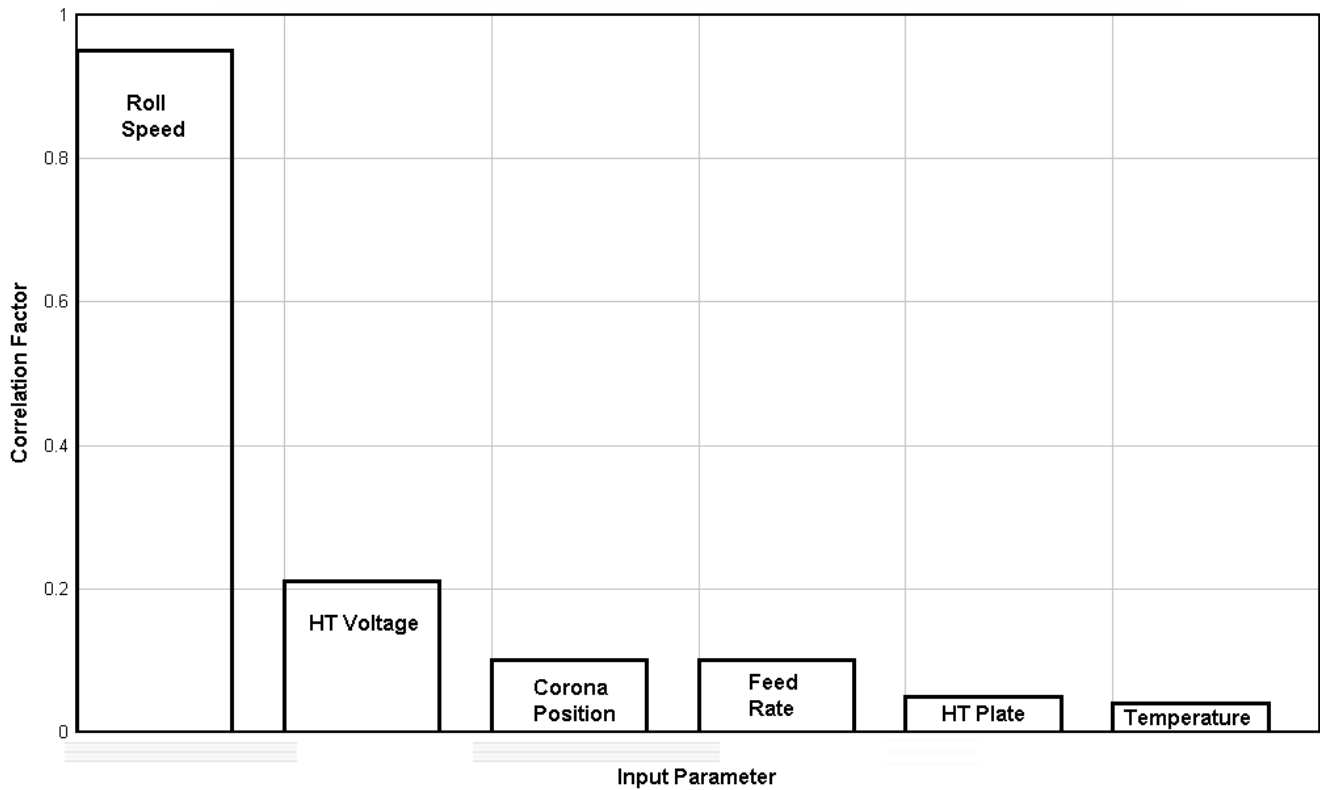

Figure 3: Impact of various factors on product grade

System Identification

A series of tests were then conducted to quantify the sensitivity of product grade and mass flow on these two most significant parameters, as well as the cross-couplings. In addition, the applicable time delays were measured. This enabled a model of the pilot plant system to be identified.

The following figures shows how roll speed and HT voltage was changed step-wise while grade and mass flow

was measured.

The impact of variation to the separation roll drive speed is shown in Figure 4. The roll drive motor speed was increased from 50Hz, in 5Hz steps, to 70Hz. As more “in between particles” were thrown off the roll, the non-conductors product stream mass flow decreased and the product grade improved inversely in steps from 88 % to 98 % in Zircon content. With the known feed grade of 81 %, the calculated recovery reduced from 93 % to 86 %.

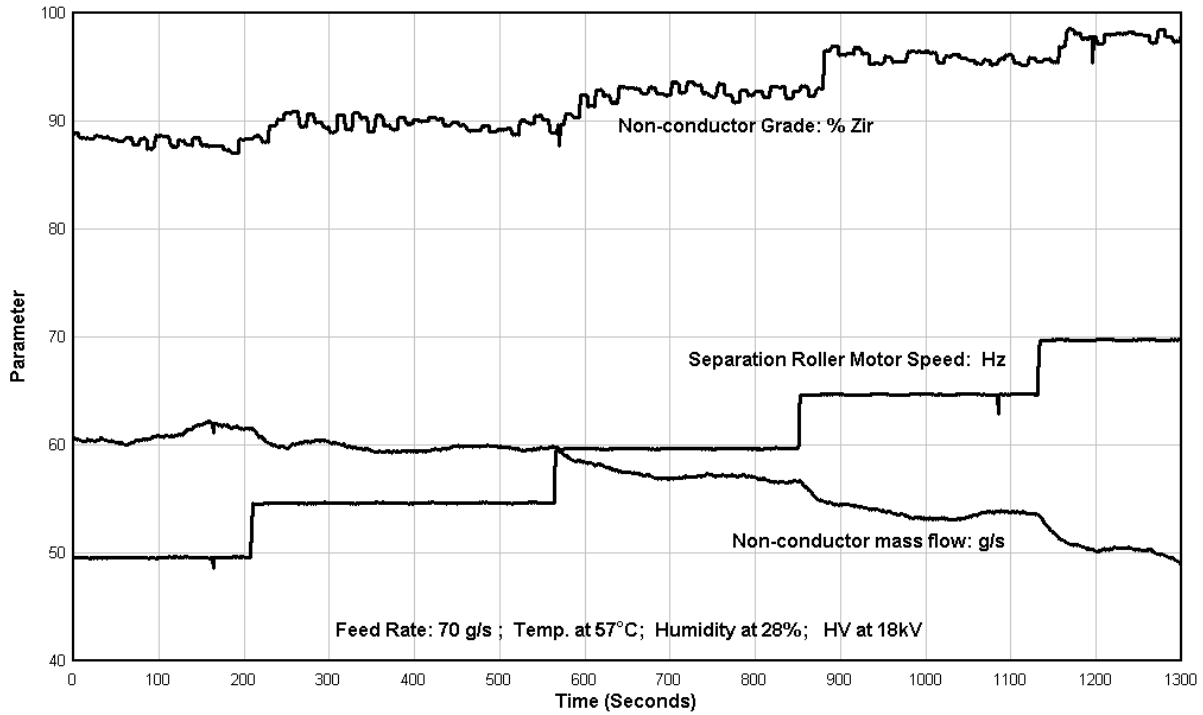

Figure 4: The impact of roll speed on separator performance

Figure 5 demonstrates the effect of the HT voltage being decreased from 21kV, stepwise to 14kV. With the lowered HT applied, less of the “in between” particles pinned to the roll and the product mass flow reduced from

63g/s down to 46g/s but product grade improved inversely from 88 % to 98 % Zircon content. However, as to be expected, recovery of Zircon dropped from 97 % to 80 %.

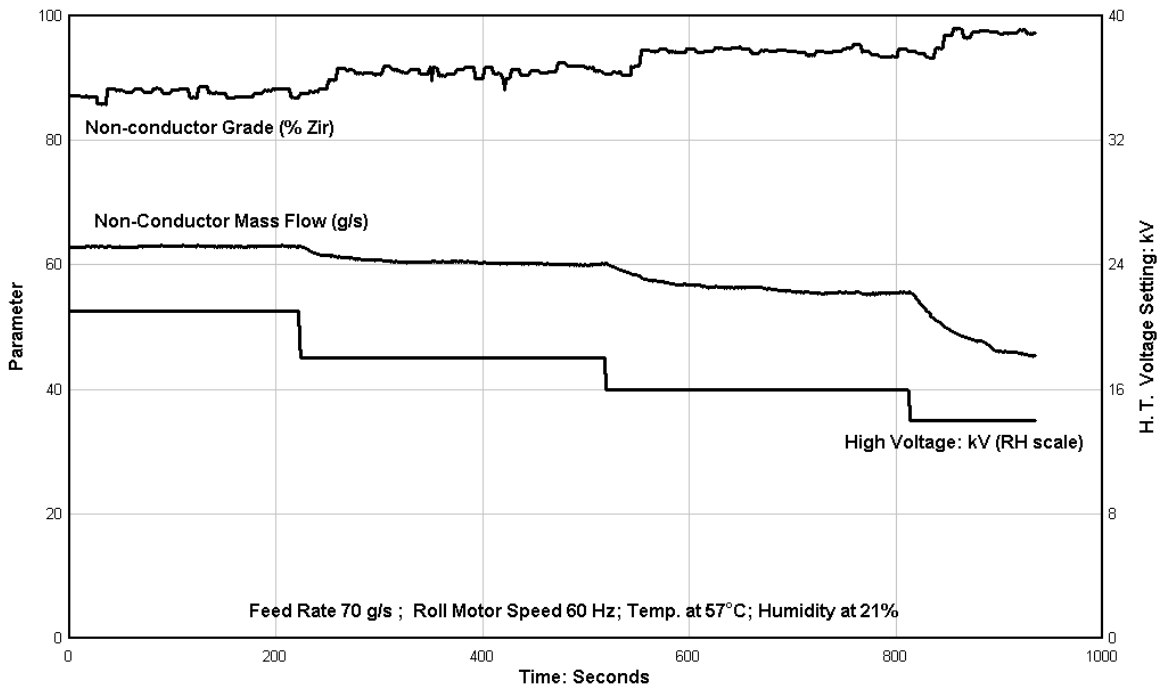

Figure 5: Impact of voltage settings on separator performance

This logical, quantified and consistent outcome could be generated within 20 minutes and gave confidence that the dream of a practical control model for HT roll separators is now a reality.

Control System

A model of the envisaged control concept is given in Figure 6.

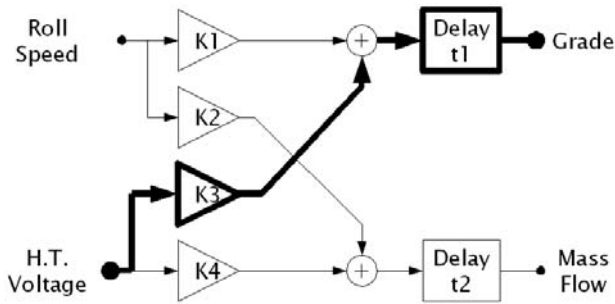

Figure 6: Basic plant model

The initial tests were used to determine the time constants of the system and the sensitivity of the roll separator to the two most important adjustable parameters,

roll speed and HT voltage. Table 1 shows that the strongest coupling occurs between HT voltage and grade. This path of strongest coupling is shown in bold lines in Figure 6. A simple single-input control of grade would therefore utilise HT voltage as the control variable, and reject any roll speed changes as a disturbance.

Table 1: Coupling Factors for the major control parameters

Coupling Factor	Roll Speed to Conductor Grade	Roll Speed to Conductor Mass flow	H.T. Setting to Conductor Grade	HT Setting to Conductor Mass flow
Average	0.507	0.453	-1.232	-1.754
Lowest	0.361	0.258	-0.875	-0.745
Highest	0.631	0.699	-1.566	-3.495

In these experiments, it was observed that plant reaction time to changes in high voltage and roll speed was about 2 seconds. The flow rate through the MQi sensor head, estimated at 4 seconds and the MQi data integration time, currently set at 9 seconds, adds up to a total lag of 15 seconds. To allow for potential system noise and to ensure stability, the overall time delay was set to 25 seconds for modelling purposes. The time constant of the scale, at 30 seconds, is comparable. The final control system is given in Figure 7.

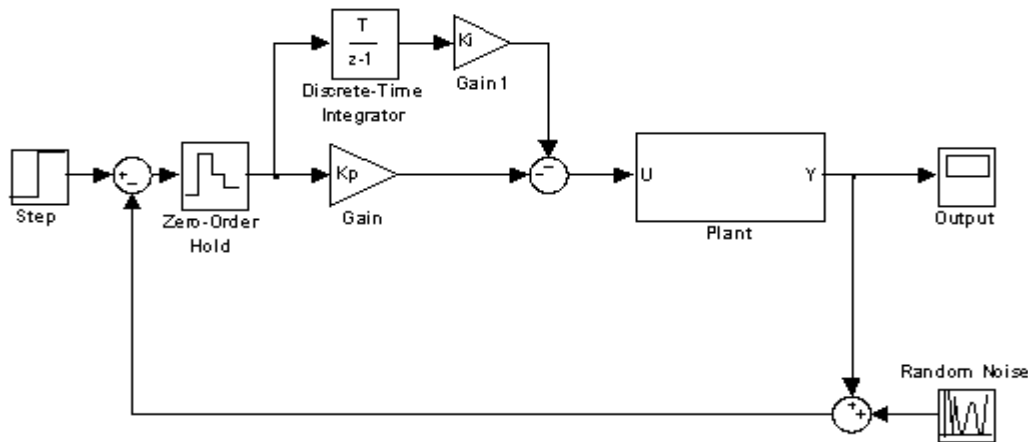

Figure 7: Control system for the pilot plant

The control system was designed to maintain a constant grade of output product (In this case the non-conductor stream) as the set point.

The data logging and control program was implemented on a laptop computer. All interfacing was done on the basis of industry standard 4-20mA loop or 0-10V analogue signals. The pilot plant is instrumented to

log and display the following parameters at a rate of 1 Hz. Output is calibrated in the stated units:

- Roll speed Drive Motor supply frequency: Hz
- Feed rate Drive Motor supply frequency: Hz
- High voltage setting kV
- Ore temperature °C

Relative humidity%
 Product flow rate g/s
 Product grade % Zircon

Test Procedure

The parameters of the control model were conservatively set as a simple integral proportional control with a time constant of 200 seconds. An integral function ensures return to the set point. No derivative function was necessary. Other parameters were then adjusted for creating disturbances.

Figure 8 shows the effect of a sharp roll motor speed

change from 65Hz to 45Hz. All other input parameters were held constant. The product grade dropped sharply from the stable condition of 92 % to 88 % Zircon. At the same time the product mass flow increases. The control action, reducing the HT voltage, then corrects the grade back to the set point over a period of 300 seconds. Mass flow adapt to the new operating conditions. The new setting ensures that on-grade production is maintained, although at a lower recovery. The rather slow control action ensures that no unstable situation arises. The small kink in the product flow graph is due to occasional product hang-ups in the discharge chutes.

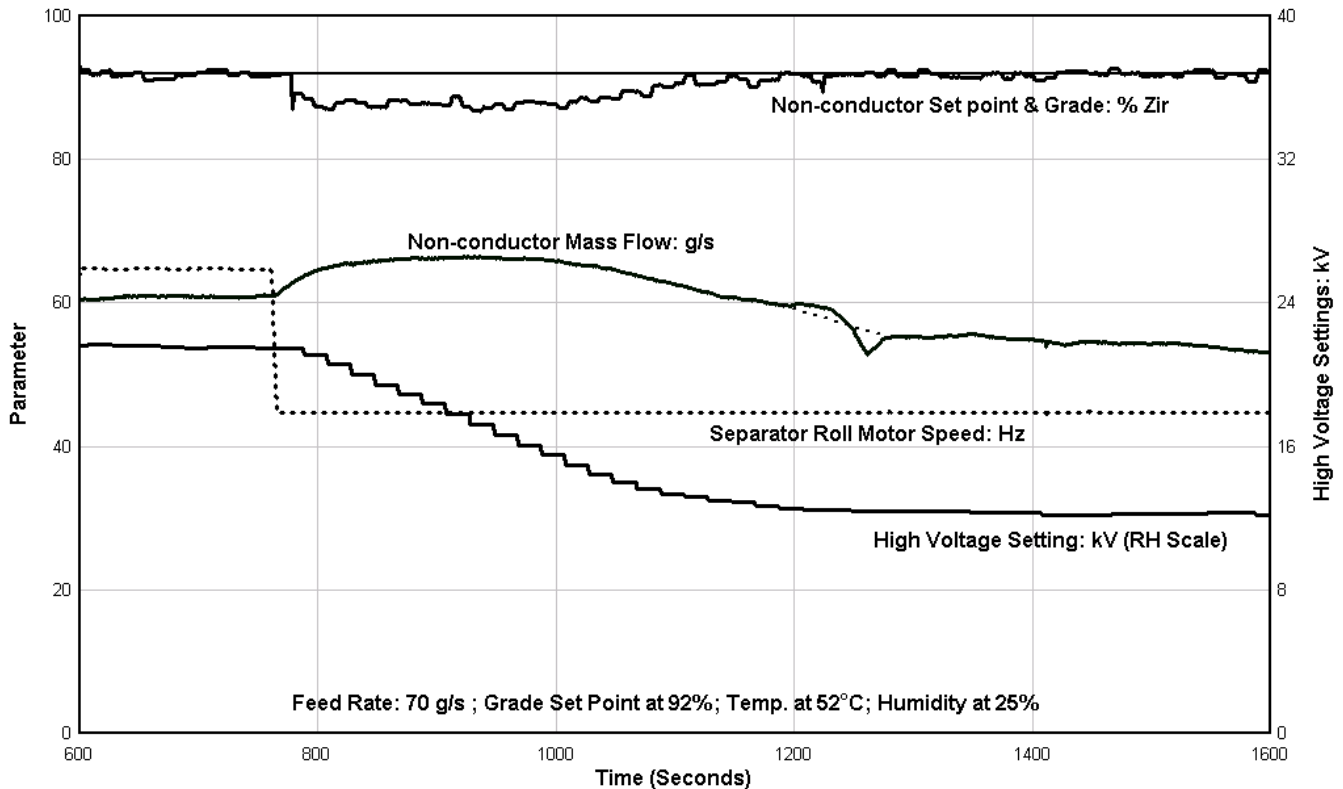

Figure 8: Grade control with speed change of separation roll

Figure 9 shows an early morning start-up with high relative humidity. The feed heater thermostat controls the feed temperature within a band of 6°C. The controller quickly stabilise the grade at the 92 % set point and maintains grade, by adjusting the HT as the relative humidity drops. The operation is stable within 10 minutes

after start-up. A step reduction in roll speed disrupts the operation but the controller adjusts the HT setting back to a new balanced setting and maintains product grade. A ripple is visible due to the thermostat control of product temperature.

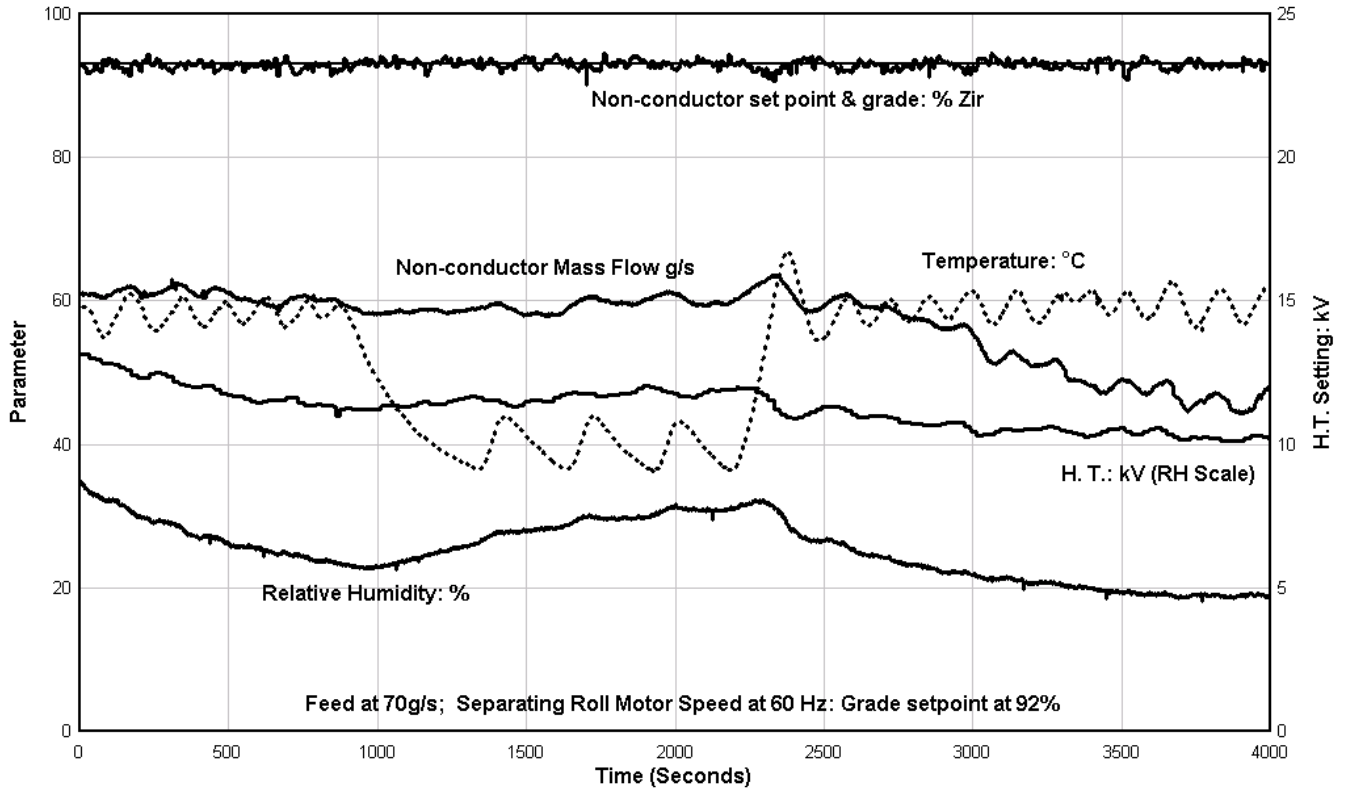

Figure 9: Grade control with varied humidity and roll speed

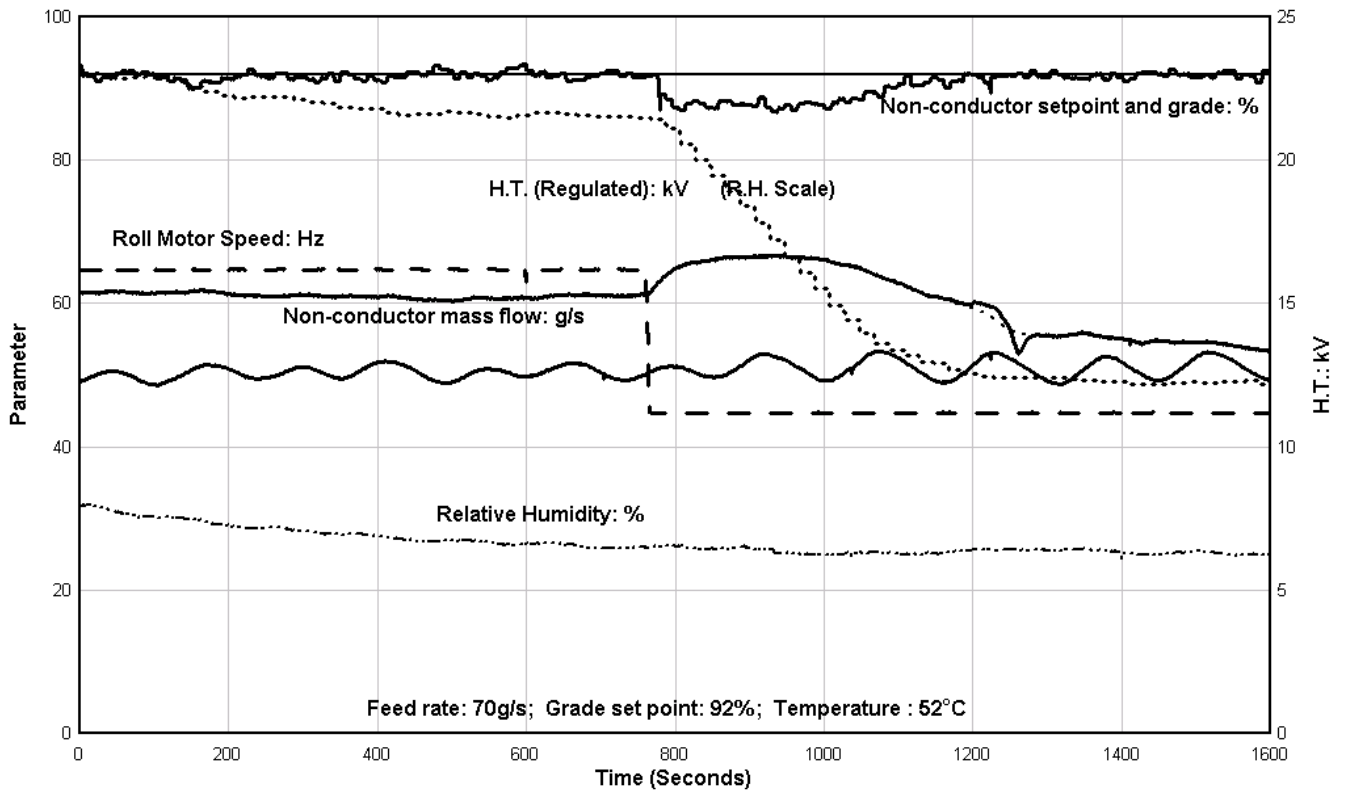

Figure 10: Grade control with variations in humidity and roll speed

Figure 10 shows how the controller handled a change in ore temperature. The relative humidity, measured within the machine housing, change inversely with the ore temperature. The controller could keep the product grade close to the set point by adjusting the HT Voltage. Product mass flow varied due to the changed conditions.

Figure 11 shows how the settings responded due to a

change in humidity and set point. The LH side of the graph shows the response due to a change in relative humidity. The ripple, due to the cyclic ore temperature regulation, is also visible. When the set point is reduced from 93 % to 87 % in one step, the voltage settings follow in small steps until the new set point is reached in about 2 minutes. Non-conductor mass flow increases accordingly.

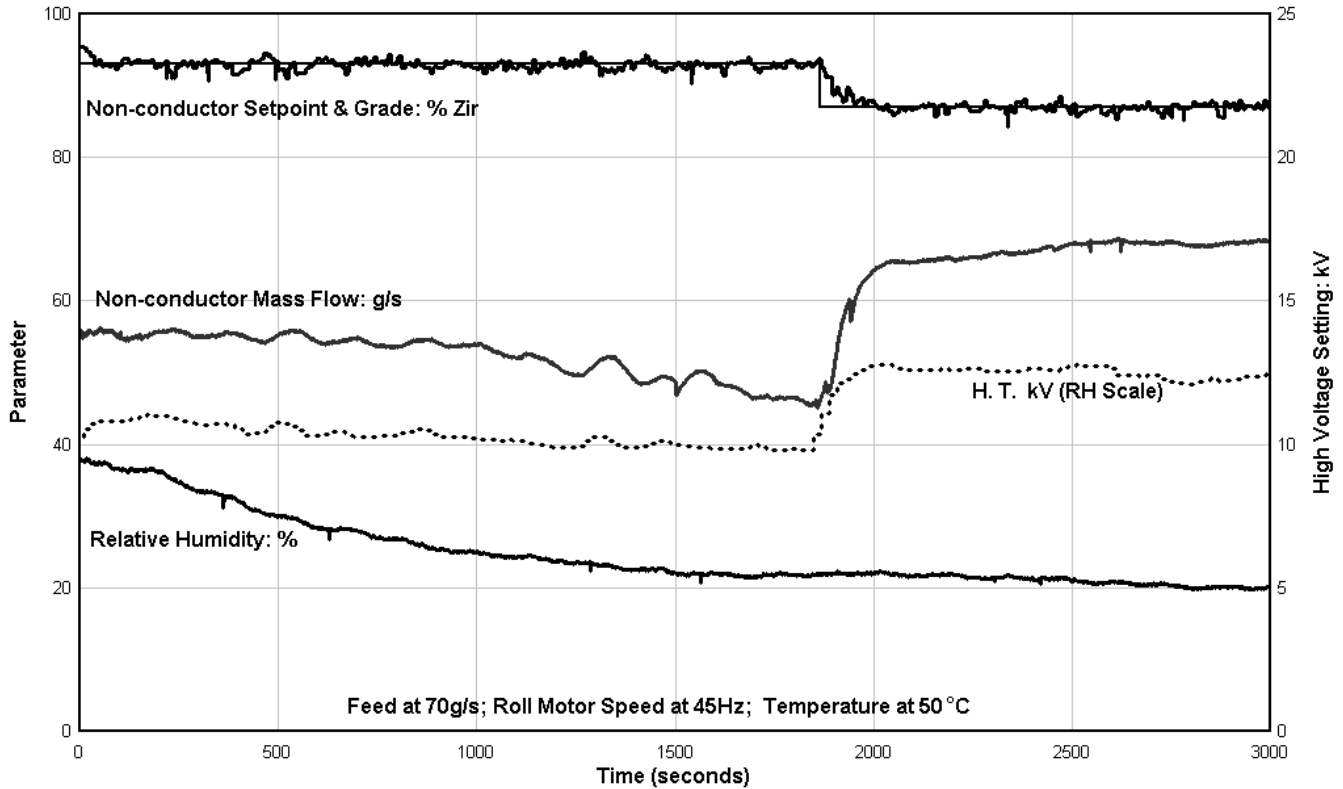

Figure 11: Control with a change in humidity and a change in set point

Figure 12 demonstrates the final concept of automatic grade control combined with manual yield optimisation. From the initial working point, product grade is controlled at 92 % Zircon content. To improve recovery, the roll speed is increased. The product mass flow shows a small drop and the grade increase above the set point. As the grade control program increase the voltage to bring the grade back to the set point, product mass flow increase and

recovery improves. Recovery is calculated and presented in real time to the operator. The same pattern repeats itself until the roll speed reach 70Hz, when recovery drops slightly although grade is still maintained. From the initial setting, the optimum for roll speed and HT has been reached with a production gain of more than 10 %, while maintaining grade.

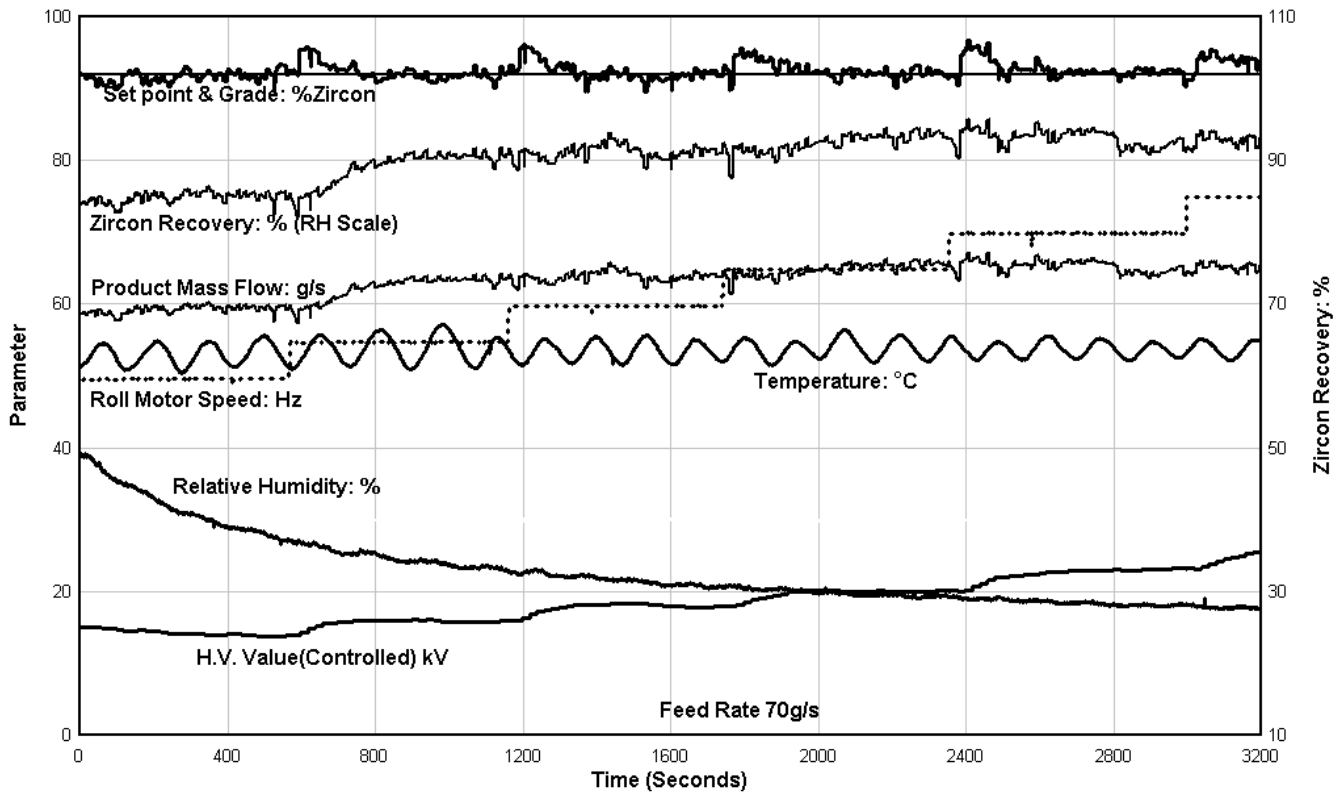

Figure 12: Settings optimised for maximum recovery

Advantages of Automatic Control

The following advantages can be realised by the application of the new technologies:

- Robust PI control of mineral grade improves plant stability
- Manual maximisation of yield is simplified
- Multi-parameter plant optimisation strategies becomes a reality

Conclusion

The tests proved conclusively that with the new in-line mineral composition quantification technology now available plus the in-line mass flow meters, HT Roll Separators can be successfully operated under automatic control and machine settings can be rapidly optimised.

Automatic grade stabilisation and yield optimisation for a HT roll separator bank requires in-line measurement of mass flow and mineralogy, as well as the implementation of a practical, robust process control system. The uncertain impact of the various parameters, influencing the operation, can be effectively mitigated by the automatic adjustment of the two most important parameters influencing machine performance, being the HT setting and the separation roll speed. With a constant

feed mass flow, the obvious optimising strategy is to regulate the product grade at the desired value by adjustment of the HT voltage. The maximum recovery (maximum product flow at grade) can be obtained by variation of the roll speed. Optimised economic return can then be obtained by changes to the other important parameters like ore temperature, relative humidity, positioning of the HT elements, splitter positions and the optimum feed rate.

Refining of the control programs with automated multiple input, multiple output “Hill climbing” optimisation strategies is the next step.

References

1. Reyneke, L., du Plessis, F.E. and van der Westhuizen, G. (2003), “Development and evaluation of technology for quantifying the mineral composition of process streams in a the typical Dry Mill in the heavy mineral industry,” *Heavy Minerals Conference, The South African Institute of Mining and Metallurgy, Symposium Series*, pp.185-190.
2. Rivitt, T. and Pax, R.A. (2003), “Implementation of control and control issues in mineral sands plants – In-line mass flow meters.” *Heavy Minerals Conference, The South African Institute of Mining and Metallurgy, Symposium Series*, pp.191-1